

The Cryogenic System for the VIRUS Array of Spectrographs on the Hobby-Eberly Telescope

Michael P. Smith^a, George T. Mulholland^b, John A. Booth^a, John M. Good^a, Gary J. Hill^a, Phillip J. MacQueen^a, Marc D. Rafal^a, Richard D. Savage^a, Brian L. Vattiat^a

^a McDonald Observatory, The University of Texas at Austin, 1 University Station C1402, Austin, TX, USA 78712;

^bApplied Cryogenics Technology, PO Box 2158, Olivia, TX, USA, 75154

ABSTRACT

The Hobby-Eberly Telescope (HET) is an existing innovative large telescope of 9.2 meter aperture, located at the McDonald Observatory in West Texas. The Hobby-Eberly Telescope Dark Energy Experiment (HETDEX) requires a major upgrade to the HET, including a substantial increase in the telescope field of view, as well as the development and integration of a revolutionary new integral field spectrograph called VIRUS. The Visible Integral-Field Replicable Unit Spectrograph (VIRUS) is an instrument comprising approximately 150 individual IFU-fed spectrographs which will be mounted on the telescope structure. Each spectrograph has a CDD camera detector package which must be cryogenically cooled during scientific operation. In order to cool each of these camera systems a liquid nitrogen system has been proposed and design study completed. The design study proposed system includes: a liquid nitrogen source, vacuum jacket distribution system, local storage on the telescope, and distribution under a thermal siphon to the individual spectrographs and local thermal connectors.

Keywords: Hobby-Eberly Telescope, VIRUS, Spectrograph, Liquid Nitrogen, Cryogenic

1. INTRODUCTION

1.1 Background

The Visible Integral-Field Replicable Unit Spectrograph (VIRUS) is an instrument comprising between 150 and 192 individual Integral Field Unit (IFU) spectrographs which will be mounted on the structure of the Hobby-Eberly Telescope (HET). The operation of this design of telescope requires that the spherical primary mirror is stationary during an observation while the corrector optics and instrument feeds move on a tracker to follow the relative motion of the sky. For this reason the input to the IFUs are at the prime focus of the telescope, some 16.5 meters from the surface of the primary mirror. The science drivers for the VIRUS spectrograph require the best possible throughput in the ultra-violet (UV) and since attenuation in the IFU fibers in the UV is a known issue there is an advantage to having the spectrographs as close to the focal plane as possible. As a result the spectrographs will be mounted to the telescope structure in two environment controlled boxes.

The spectrographs each consist of an IFU input, collimator, VPH grating and Schmidt Camera. The camera corrector plate performs the role of the cryostat window. The camera mirror, field flatter and detector package are inside the cryostat. The detector package is mounted on a spider and is thermally isolated from the spider and the rest of the camera. A copper cold finger provides the cold link between the cold source and the detector package. A prototype VIRUS spectrograph has been built and has been in service at the McDonald observatory since the end of 2006. The prototype uses a local, liquid nitrogen filled Dewar (refilled daily) which would not be practical in the scaled up version of the full VIRUS.

The baseline design of the VIRUS spectrographs has converged on pairing up the spectrographs. This facilitates sharing certain components (electronics, vacuum, cryogenic), improves the packing factor, reduces the number of manufactured parts, and allows for more cost-efficient manufacturing processes. For the cryogenic system the pairing up of the

spectrographs places a higher load on the local connection to the cryogenic system but halves the number of cold connection positions required.

1.2 The Design Study

The basic engineering problem of cooling 150 spectrograph detectors to approximately 170K in difficult to service locations could be solved in many ways. The key was to find a solution which would be ultra reliable and cost effective without being overly cumbersome. A liquid nitrogen system seemed an obvious contender and would be a natural extension of the prototype design. In addition to liquid nitrogen systems, McDonald has had experience with closed cycle cryo-coolers. There have also been some very interesting developments in small pulse-tube cryo-coolers and other systems for space applications. We desired to explore all reasonable options before choosing a system.

After some initial research and discussion with vendors, McDonald Observatory decided to contract with Mr. George Mulholland of Applied Cryogenics Technology to undertake a design study of a baseline liquid nitrogen system and, as a secondary task, to explore other cooling alternatives. After some research, consulting with colleagues and drawing on his experience, he converged on the decision that a liquid nitrogen system would be the best solution and merited further design. The main reasons were its lower cost, high reliability, low risk and an absence of vibrating parts.

With a liquid nitrogen system, the first question was determining the type and position of the liquid nitrogen source. The options were: trucking in liquid nitrogen from an off-site vendor and storing a reasonable volume in a Dewar close to the telescope, or installing an on-site nitrogen liquefaction plant. The liquefaction plant was attractive due to the location of the observatory, far from liquid nitrogen vendors and independence from delivery vendors. Liquefaction, however, required a large plant* for the volume of liquid nitrogen required, it still required a large Dewar to provide a buffer in case of maintenance or failures, and had a very high cooling water and electricity demand. The on-site liquid nitrogen generation system was budgeted and found to be approximately 30% more costly over a five-year period than trucking in liquid nitrogen. A Dewar, large enough to receive an entire truck load of liquid nitrogen, was found to be the most cost-effective source for liquid nitrogen.

1.3 System Overview

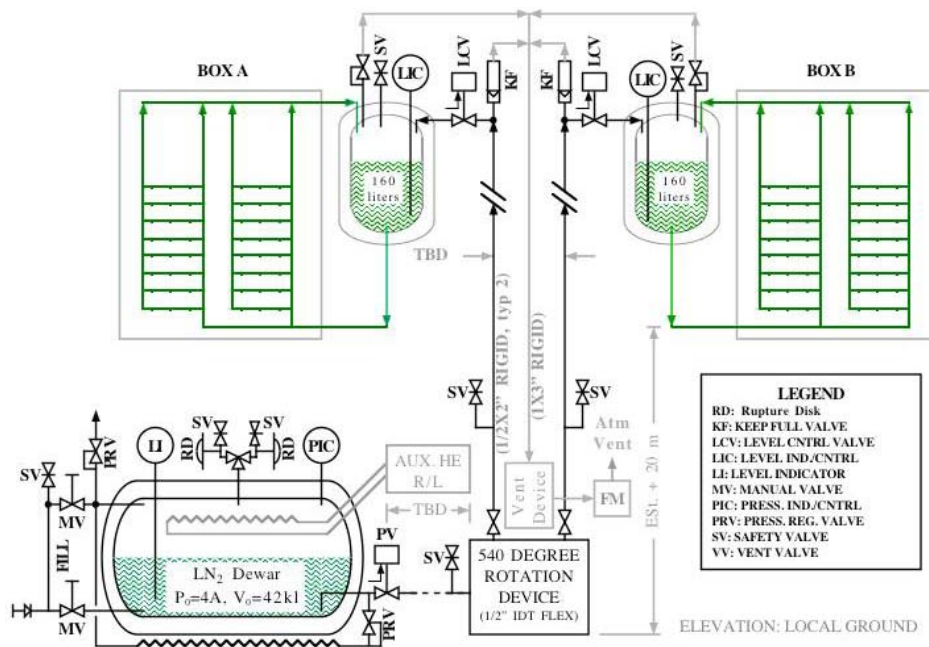

Fig. 1. VIRUS baseline cooling, simplified P&ID

* A Stirling Cryogenics and Refrigeration system was investigated in detail after it was found to be the most suitable system in our consumption range

The VIRUS cryogenic system consists of liquid nitrogen storage Dewar, a vacuum-jacketed transfer line to maintain liquid nitrogen levels in small local Dewars, a thermal siphon system to distribute liquid nitrogen to the individual spectrograph pairs, and a local make-break thermal connector at each spectrograph pair. The thermal siphon vessels are located at each spectrograph enclosure on the telescope.

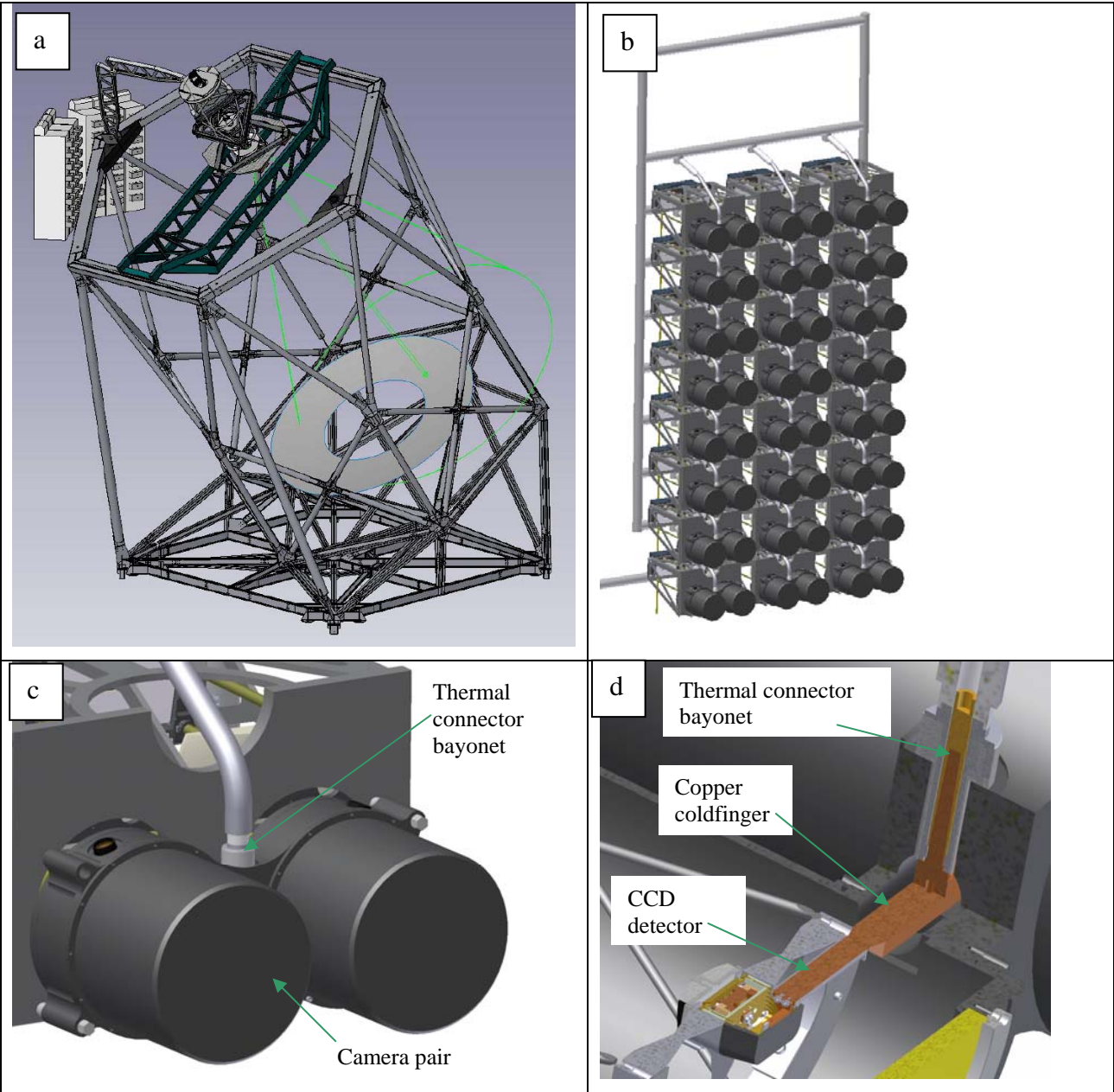

Fig. 2a. Proposed position of one of the two sets of spectrograph enclosures on the HET. 2b. VIRUS array on one manifold, representing one quarter of the proposed spectrographs. 2c. Camera pair showing attachment of thermal connector. 2d. Coldfinger inside the camera cryostat, linking thermal connector to the detector package.

2. COOLING SOURCE AND TRANSFER

A storage Dewar external to the telescope building is required to store a supply of liquid nitrogen for cooling the VIRUS detectors. The total cooling power of the cameras may be as high as $192 \times 5W = 960W$ but for the entire system with all its losses accounted for and a 50% margin, the cooling source is required to deliver 3600W of cooling power. An automatic transfer system will take the liquid nitrogen to the spectrograph enclosures where it is distributed.

2.1 Cooling Media - Liquid Nitrogen

Liquid nitrogen boils at 75.3K at 0.7845 std. atmos at the McDonald Observatory elevation. This temperature is ideal for this application as it leaves an ample delta T to the desired temperature of the detector. It has large liquid latent heat of vaporization which will efficiently remove heat from the detector. Liquid nitrogen's nucleate and film boiling properties are available in the literature and are critical in determining the contact surface area requirements for the heat exchanger in the thermal connector.

2.2 Liquid Nitrogen Supply and Storage

A standard modern 11,000 gallon, low pressure, low heat loss Liquid Nitrogen Dewar was selected. The Dewar size allows for a full load from a 6,000 gallon tanker as well as a comfortable minimum inventory and sufficient operational gas space. It is estimated that two to three full tanker deliveries will be required per month to supply the estimated refrigeration load. The supplier typically monitors the liquid level by telemetry and automatically schedules full trailer deliveries to maintain the desired inventory level. The Dewar will be located outside of the telescope building beyond the control building and will need good trailer access for refilling.

The standard Dewar includes modest equipment to maintain its source and vent pressures and requires no additional utilities, instruments or controls to do so. The Dewar provides constant supply of Liquid Nitrogen to the thermal siphon vessels under its own pressure, driven by the pressure increase due to the nitrogen gas formation in the Dewar. This pressure is controlled by a pressure relief valve and can be increased by an auxiliary heater. The steady state Dewar loss is 0.15% per day

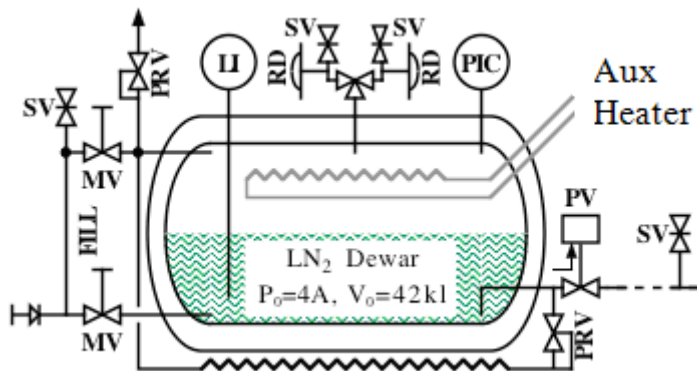

Fig. 3. P&ID of storage dewar

2.3 Transfer Lines

Beginning at the Dewar outlet valve, a Vacuum Jacketed (VJ) "U" jumper[†] connects to the start of the long run VJ line that encircles the control building and penetrates the building and the pier directly below the telescope. The long run transfer line terminates in a bayonet connection and connects to a vacuum-jacketed flex line. The flex line is threaded through the telescope azimuth cable wrap to provide the 540° rotation requirement. The exit from the wrap meets two VJ rises which run up to the two thermal siphon at the spectrograph enclosures.

[†] all VJ connectors are made by cryogenic bayonets

3. THERMAL SIPHON AND COOLING MANIFOLDS

Local detector cooling is addressed by a two-phase liquid nitrogen in a thermal siphon (TS) arrangement. Maintaining the level of the TS vessel is all that is required to gravity feed liquid nitrogen to manifolds that in turn feed individual detector loads. The TS accepts the returning fluid, recovering the liquid and returning the vapor to the vent return line. This two phase (liquid to gas) process utilizes the liquid nitrogen heat of vaporization (ca. 200j/g at TS operating pressure) and discards the cold vapor without using the cooling available in the ca. 80K vapor. The vapor is returned through VJ lines to the outside of the telescope and heated to the ambient temperature before venting.

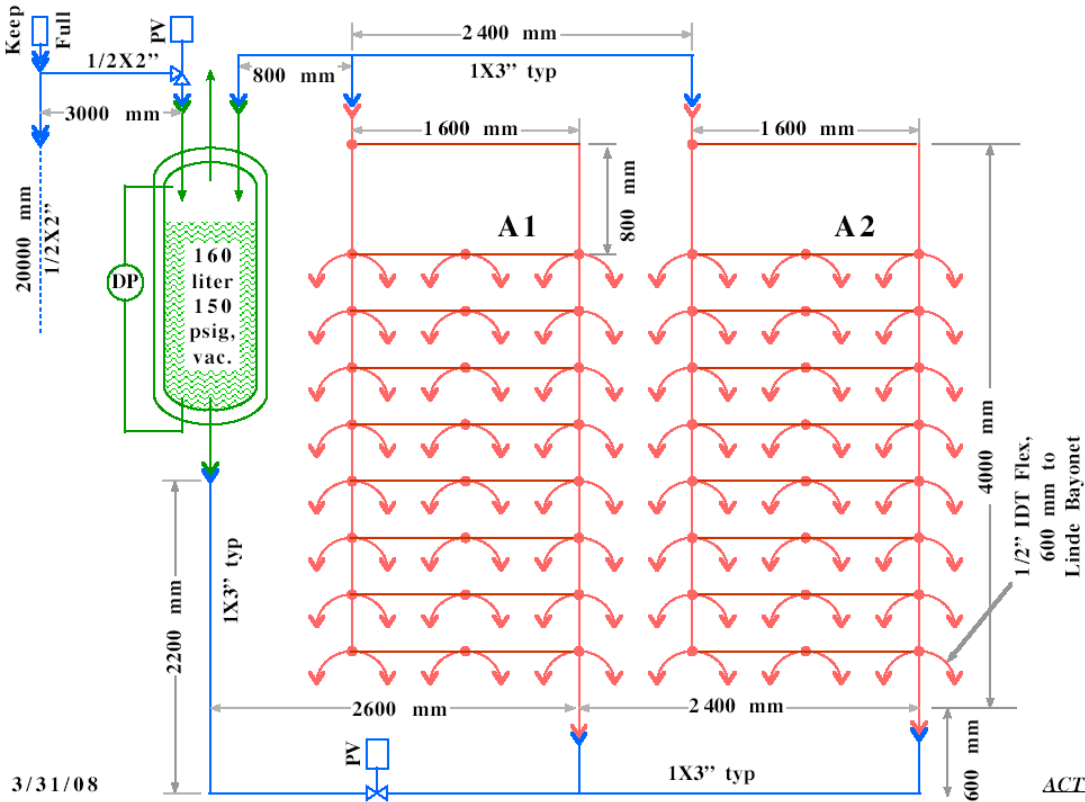

Fig. 4. VIRUS thermal siphon & VJ liquid nitrogen distribution. Box “A”

3.1 Thermal Siphon Vessel

The TS vessel serves as a local liquid nitrogen receiver to continuously supply the cooling manifolds with liquid nitrogen. Its most important function is separating the liquid entrained in the gas from the two-phase return lines and it must be able to achieve this at the highest required flow rate.

Each TS vessel is monitored by a main level transmitter and maintained full by a fill control valve fed from the higher pressure storage Dewar. There are redundant sensors to avoid overfilling and redundant shutoff valves on the risers (to independently isolate each TS vessel) and Dewar feed line. The size of the vessel was chosen to be 160 liters so that when operating with 120 liters it has an inventory for 2.5 hrs. This allows a 40-liter volume for phase separation.

3.2 Cooling Manifold

Each TS vessel continuously feeds liquid to two risers. Each riser feeds eight laterals with three coldfinger extensions (CE) on each, and each CE feeds a camera connection at the individual spectrograph pairs. The laterals feed into a common riser which will contain two-phase nitrogen as the heat load on the laterals has caused significant vaporization. The laterals have sufficient cross section to contain a mix of liquid and gas, with the gas rising to the top and liquid filling the spectrograph flexible CE lines. The lateral will have a weir type arrangement so that the liquid riser remains

free of vapor and all the vapor escapes out of the two-phase riser. All the risers meet a horizontal return line to the TS vessel where separation of any remaining liquid occurs.

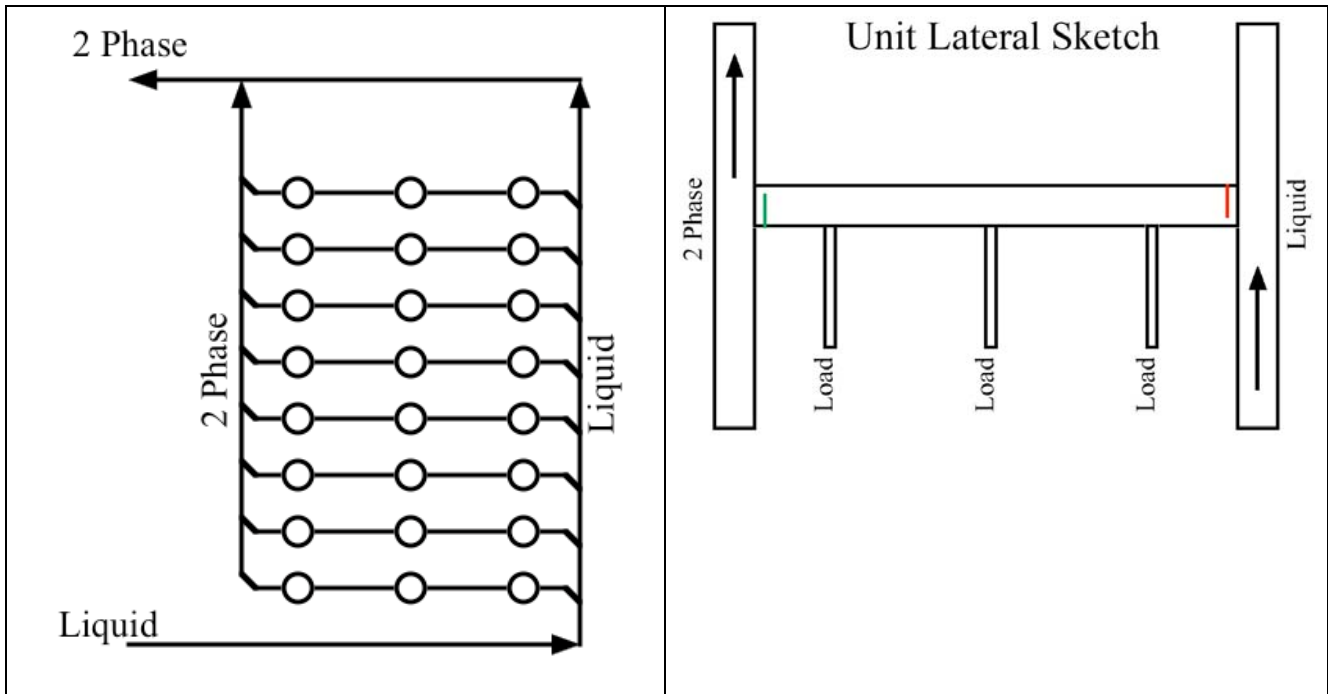

Fig. 5a. Manifold layout showing liquid and 2-phase risers

5b. Lateral showing weir layout and camera load positions.

3.3 Cold Gas Vent

After separation at the TS vessels, the vapor at ca. 80K must be removed from the telescope so as not to affect the dome seeing. (We plan to investigate using the cooling potential of the gas to cool the electronics associated with the spectrographs but that will not be assumed here.) The gas, which has a significantly larger volume than the incoming liquid, is vented down to the base of the telescope in a VJ line where it is heated to the ambient temperature in a few kW temperature-controlled heat exchanger. The exhaust gas from the heat exchanger will be passed through the pintle bearing from where it will be vented away from the telescope building. Venting the nitrogen gas also decreases the risk of reducing the oxygen levels in the dome, making it a potentially dangerous working environment.

3.4 Safety Provisions

Whenever large quantities of liquid nitrogen are piped through a habited building, there are necessarily safety concerns. Large volumes of spilled nitrogen can displace oxygen, affecting the clear thought and consciousness of inhabitants. The first line of defense against spills is sound equipment and design. All vessels and piping systems will be pressure tested and certified to the relevant codes. All vessels are double walled, which will capture the nitrogen in the event of internal pipe failures.

A series of oxygen monitor sensors will be employed and monitored on the floor of the dome as well as around the spectrograph enclosures to detect any local problem and sound an alarm. A persistent alarm will close the Dewar source valve.

4. THERMAL CONNECTION

The thermal connection (TC) between the thermal siphon manifold and the detector requires efficient transfer of the cooling power of the liquid nitrogen to the detector as well as providing a separation point. It is a requirement of the VIRUS spectrograph that each camera should be independently removable for maintenance and deployment. It is also required that the removal/connection should be achieved while the rest of the spectrographs remain cold and

undisturbed. A system has been developed that combines a standard flexible VJ line to a standard cryogenic bayonet incorporating custom copper thermal connector contacts into each end of the bayonet. When the bayonet halves are brought together they close the thermal contact. The resulting system is completely closed, i.e., it is externally dry with no liquid nitrogen exposure. The camera end of the connector is connected by a copper cold finger to the detector.

Two connector types have been proposed and will be investigated further through design and prototyping. Of concern is the requirement that any camera can be placed at any manifold position and hence the connectors need to be insensitive to matching of a specific pair. The first connector type uses conduction through a direct copper-to-copper contact and requires a controlled interface. The second, the gas conduction TC uses a controlled gap between the connector halves. The gap is filled with helium and conduction is through the helium gas.

4.1 Flex Line and Heat Sink

In order to keep the copper path length as short as possible it was desired to have the liquid nitrogen-to-copper heat sink as close to the connector as possible. Using the VJ SuperFlex line made it possible to essentially have the heat sink right at the connector while still maintaining flexibility and facilitating attachment and removal of the connector. The design of the sizing of the heat sink is critical in order to assure that liquid nitrogen is able to fill the super flex line and make good liquid to copper contact at the copper interface to ensure good conduction. The heat load to surface area required for nucleate boiling are well understood and for our 10W load for the camera pair $\sim 15\text{cm}^2$ of contact surface is required to ensure that the system is not permanently in the film boiling regime. Assessing the power limits to maintain and reach nucleate boiling will be the subject of early prototyping. It is important to note that the bayonet must be oriented vertically with the liquid nitrogen side up in order to function properly. The liquid evaporation must be allowed to flow monotonically up in order to avoid a vapor lock.

4.2 Direct Contact TC

Commercial cryogenic bayonets are routinely used to connect sections of VJ piping. The standard application has the connection made dry; then the liquid nitrogen is introduced and flows through the connector. In this application the bayonet is used to hold two copper connector halves and the bayonet is used to provide the insulation through its long path of thin walled stainless steel. The bayonet also provides the connection to the vacuum on each side.

The 0.5in ID Linde Bayonets provide an ideal starting point for the design. They are fitted with a radial “O” ring that seals the male half of the bayonet to the female half *without* requiring that the internal pipe sections be fully seated. This allows the copper connector halves to contact before the bayonet bottoms out, enabling a quantifiable force to be exerted on the copper-copper interface. The copper surface will be polished and gold plated to improve conduction. From conversations with industry experts and unpublished experimental data, we believe we can control the Delta T across this interface to below $\sim 10\text{K}$.

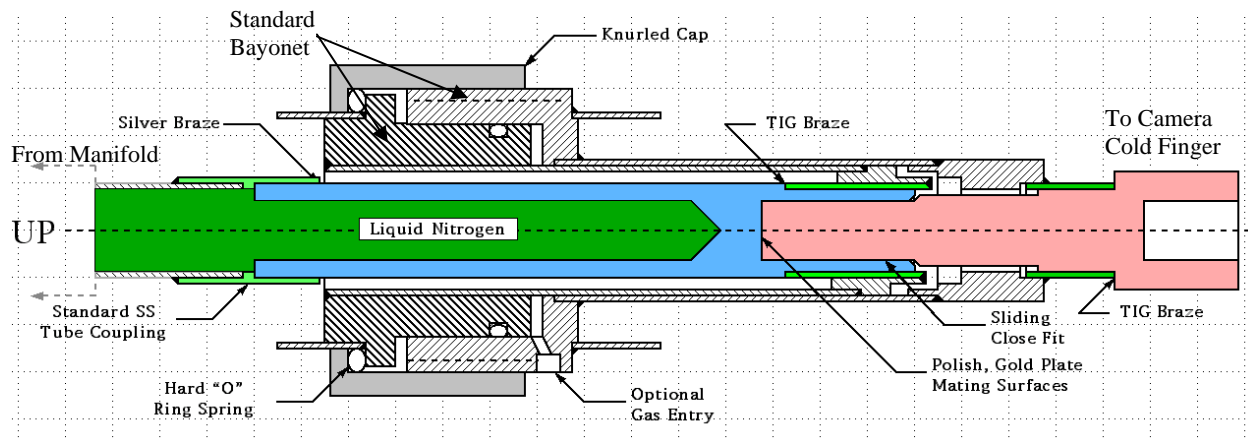

Fig. 6. Direct contact thermal connector

4.3 Gas Conduction TC

The gas conduction CT is similar to the direct contact TC in its use of the Linde Bayonet. The difference is the longer connector extension into the bayonet to provide additional surface area. The gap between the two halves of the connector

is controlled to an average of ~2 mil. This can be achieved with standard machining. The connector may or may not touch at some points but since the conduction is to be through the gas this is not critical. Once the two halves of the connector have been brought together, a small vacuum pump evacuates the area between the connector halves and helium gas is flushed in. Note that helium gas has a thermal conduction of 7.35 times that of air. On the negative side, the longer connector length will require the use of a longer bayonet.

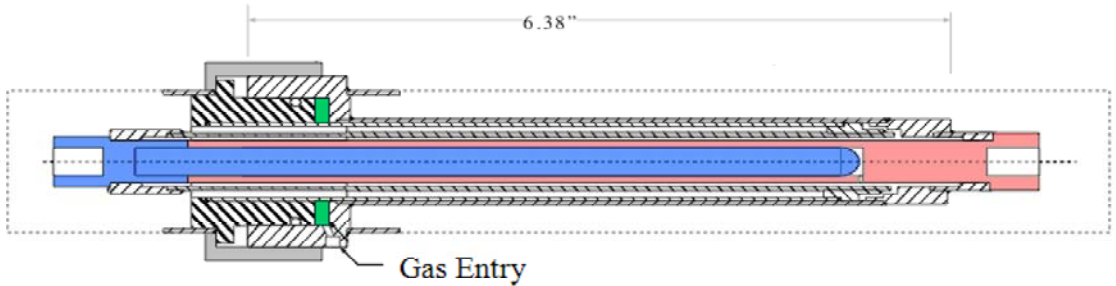

Fig. 7. Gas conduction TC showing gas entry and 6" bayonet

4.4 Gravity Switch

The design of the connector lends itself to a very interesting feature, namely that when the connector is held horizontally down, it operates as intended. But when the connector is lifted horizontally with the end pointing up, the vapor generated at the heat sink quickly causes a vapor lock and the connector becomes ineffective. We can use this property as a switch to stop cooling through a connector once it is disconnected from its camera. Once removed it is hung up and will warm up. In practice we will immediately cap the ends to avoid frosting.

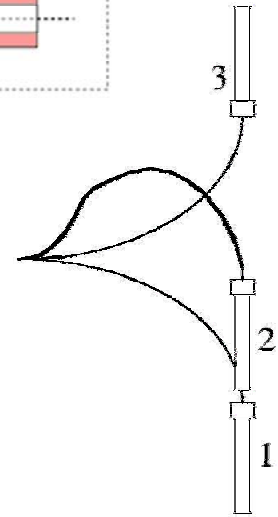

Fig. 8. Gravity switch. 1) Inserted into camera. 2) Removal 3) Stow warm position

5. PROTOTYPING AND SYSTEM DEVELOPMENT

Prototype testing is required to demonstrate specific aggressive design issues before proceeding with the design to manufacture.

5.1 SuperFlex – Thermal Connector Prototype

A prototype of the SuperFlex – bayonet thermal connector system is being built to test the limits of its cooling power. The prototype will have a gravity feed header tank, a length of SuperFlex VJ line connected to the male bayonet fitted with a half connector. Integral to this half connector will be the heat sink. The female bayonet fitted to the other half of the thermal connector will be installed in a test cryostat. The connector will be instrumented with a heater and temperature sensor. There will be numerous temperature sensors on both sides of the TC and on the heat sink. The heater will have sufficient range to heat the connector with four times the expected power of the detector system.

There are a number of specific concerns that this prototype will address:

- 1) Using a single 0.5in ID Super Flex as both the Liquid Nitrogen supply and vapor return line will result in liquid being entrained in the gas which will have a significant volume and velocity. This test will enable the limiting power at which the liquid is no longer able to fill the SuperFlex and heat sink to be determined.
- 2) The cooling power of the heat sink at the copper connector will be limited by the nucleate boiling/film boiling limit. The prototype will enable us to determine when the system changes from nucleate to film boiling, both as a function of power. This function will be determined for both increasing and decreasing power and the response is expected to be direction dependant.

3) The thermal connector performance as a function of power will be determined by measuring the delta T across the TC.

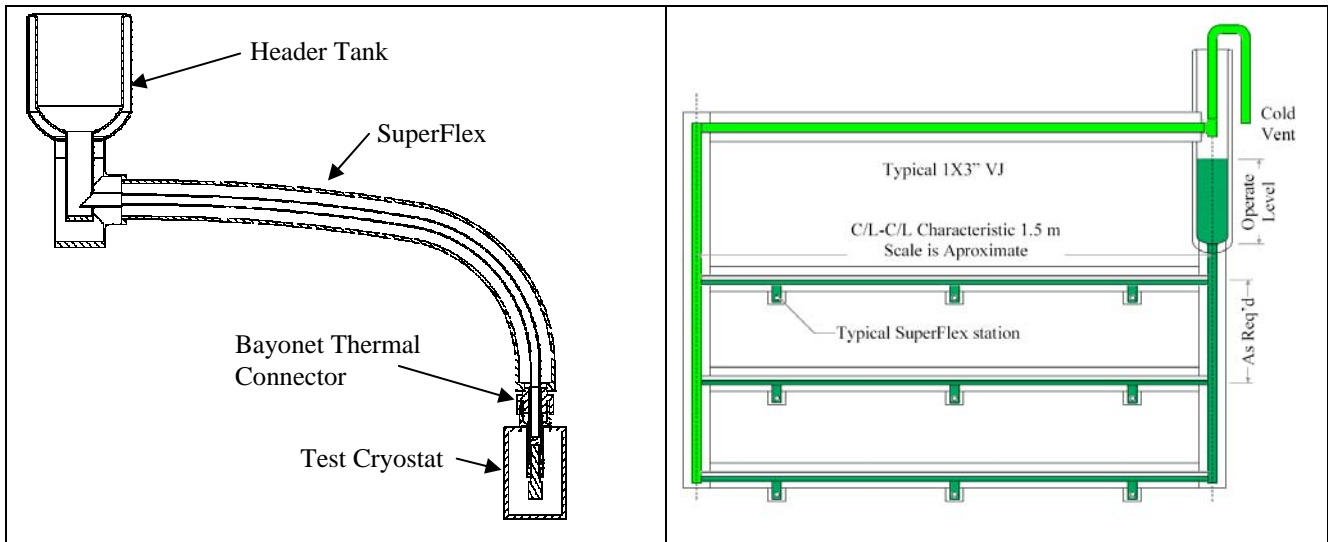

Fig. 9a. Liquid nitrogen header tank prototype to test performance of the SuperFlex, heat sink and thermal connector. 9b. Manifold power and flow test fixture to test performance of lateral manifolds and two-phase fluid removal.

5.2 Manifold Prototype

A simplified scale prototype of the two-phase lateral and thermal siphon system will be built. This test will be used to determine the correct sizing for the laterals and vertical risers. There will be three (instead of eight) laterals and each SuperFlex station will be replaced with a heater. The prototype will determine the ability of the system to keep full with sufficient liquid nitrogen to adequately feed the SuperFlex stations.

5.3 Development Plan

These prototype tests are intended to reduce the risk of the aspects of the system that are unproven and considered to be of high risk. Industry standard equipment and practices will be used wherever possible. The storage Dewar, VJ transfer lines and thermal siphon vessel are well understood industrial systems and will be made exclusively using standard components and practices. The thermal connector and two-phase liquid nitrogen systems will require prototype testing in order to further their design.

The authors wish to thank Ray Radebaugh of NIST for his valuable contributions to the design study.

REFERENCES

1. G. M. Mulholland , *VIRUS Cryogenic System Design Study Task 1B Final Report*
2. G.J. Hill, P.J. MacQueen, P. Palunas, M.D. Shetrone, J.A. Booth, "Present and future instrumentation for the Hobby-Eberly", Proc. SPIE, 6269, 622907 (2006)
3. G.J. Hill, P.J. MacQueen, J.R.Tufts, A. Keltz, M.M. Roth, W. Altmann, P. Segura, K. Gebhard, P. Palunas, "VIRUS:a massively replicated integral-field spectrograph for HET. Proc. SPIE 6269, 62692J (2006)